



US008052120B2

(12) **United States Patent**
Bacon

(10) **Patent No.:** **US 8,052,120 B2**
(45) **Date of Patent:** **Nov. 8, 2011**

(54) **MULTIPURPOSE MODULAR LIFT PLATFORM**

(75) Inventor: **Todd J Bacon**, Northville, MI (US)

(73) Assignee: **Herkules Equipment Corporation**,
Walled Lake, MI (US)

(*) Notice: Subject to any disclaimer, the term of this patent is extended or adjusted under 35 U.S.C. 154(b) by 252 days.

5,299,906 A	4/1994	Stone	
5,482,303 A	1/1996	Meloy	
5,829,948 A *	11/1998	Becklund	414/607
6,112,858 A *	9/2000	Arnst	187/269
6,286,812 B1 *	9/2001	Cherry	254/9 C
6,669,214 B1	12/2003	Domis	
6,857,493 B2	2/2005	Shupp et al.	
7,070,167 B1 *	7/2006	Bacon et al.	254/93 HP
7,070,189 B2 *	7/2006	Grauss	280/32.6
7,374,184 B2	5/2008	Worthy	
7,789,811 B2 *	9/2010	Cooper	482/89
2002/0043776 A1	4/2002	Chuang	
2005/0134011 A1	6/2005	Lin	
2009/0278098 A1 *	11/2009	Bacon	254/1

(21) Appl. No.: **12/435,527**

(22) Filed: **May 5, 2009**

(65) **Prior Publication Data**

US 2009/0278098 A1 Nov. 12, 2009

Related U.S. Application Data

(60) Provisional application No. 61/051,597, filed on May 8, 2008.

(51) **Int. Cl.**
B66F 3/35 (2006.01)

(52) **U.S. Cl.** **254/93 HP**; 254/122; 280/43.12; 280/32.6; 180/168; 414/607

(58) **Field of Classification Search** 254/93 HP, 254/122, 124, 126, 93 R; 280/43.12, 32.6; 180/168; 414/607; 187/269

See application file for complete search history.

(56) **References Cited**

U.S. PATENT DOCUMENTS

4,243,354 A	1/1981	Garcia
4,302,023 A	11/1981	Kiesz
4,488,326 A	12/1984	Cherry
4,639,005 A	1/1987	Birlkey

FOREIGN PATENT DOCUMENTS

JP	09-110391	4/1997
JP	09110391	4/1997
JP	3065742	11/1999
JP	03065742	11/1999

(Continued)

OTHER PUBLICATIONS

International Search Report, International Application No. PCT/US2009/042833, Sep. 25, 2009, 2 pages.

Primary Examiner — Lee D Wilson

(74) *Attorney, Agent, or Firm* — Howard & Howard Attorneys PLLC

(57) **ABSTRACT**

A vertical lift mechanism (100, 100a, 100b) including: a lift support assembly (102) comprising an upper frame member (104), a lower frame member (106), the upper frame member is movable between a lowered position and a lifted position. The lift support assembly additionally includes a support mechanism (150) that holds and maintains the alignment between the upper frame member and a lower frame member as well as a powering unit to cause movement of the upper frame.

10 Claims, 12 Drawing Sheets

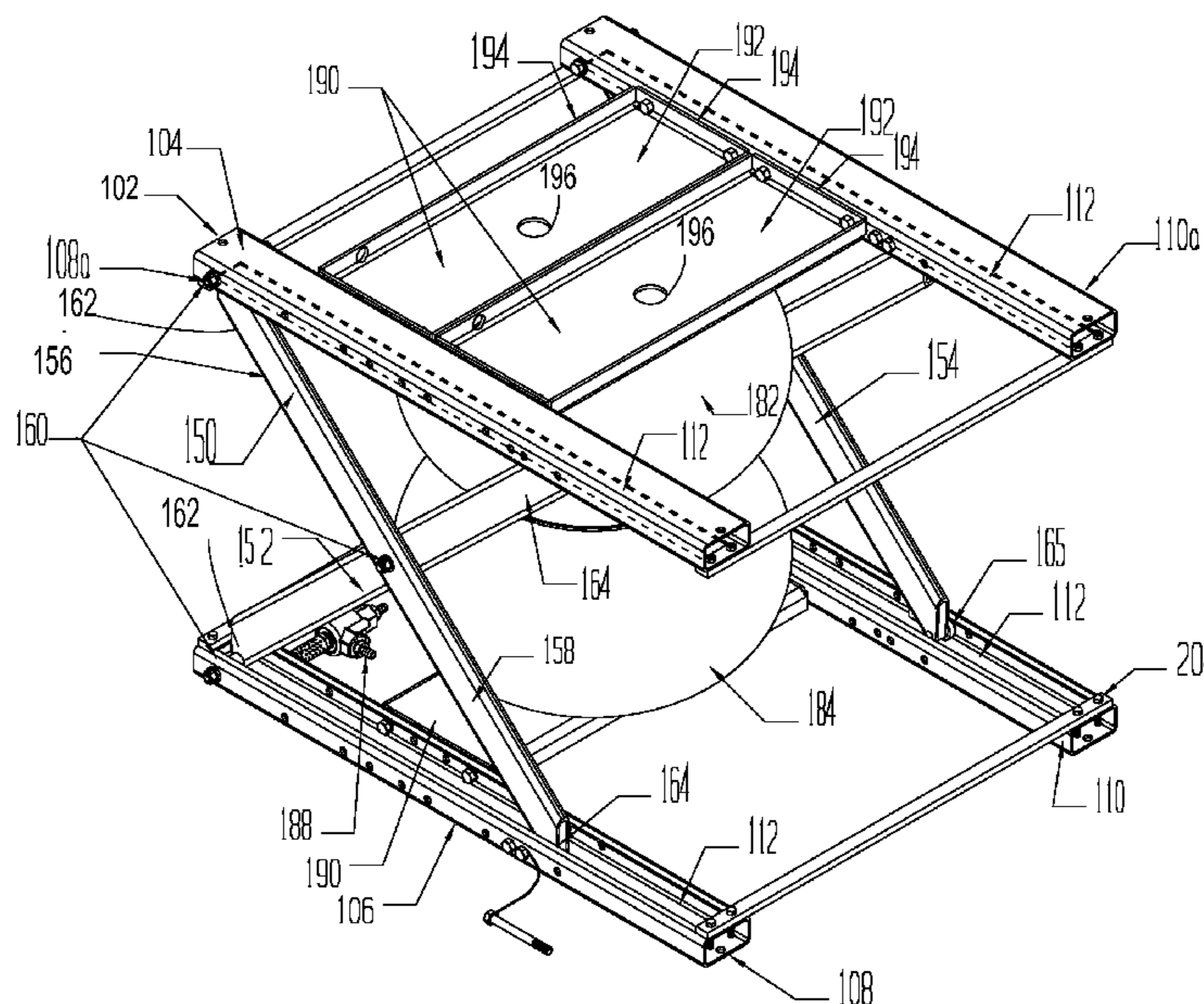

US 8,052,120 B2

Page 2

FOREIGN PATENT DOCUMENTS					
			JP	2005006459	3/2008
			KR	1994-0001675	3/1994
			KR	2019940001675	3/1994
			* cited by examiner		
JP	2003-128390	5/2003			
JP	2003128390	5/2003			
JP	2008-56459	3/2008			

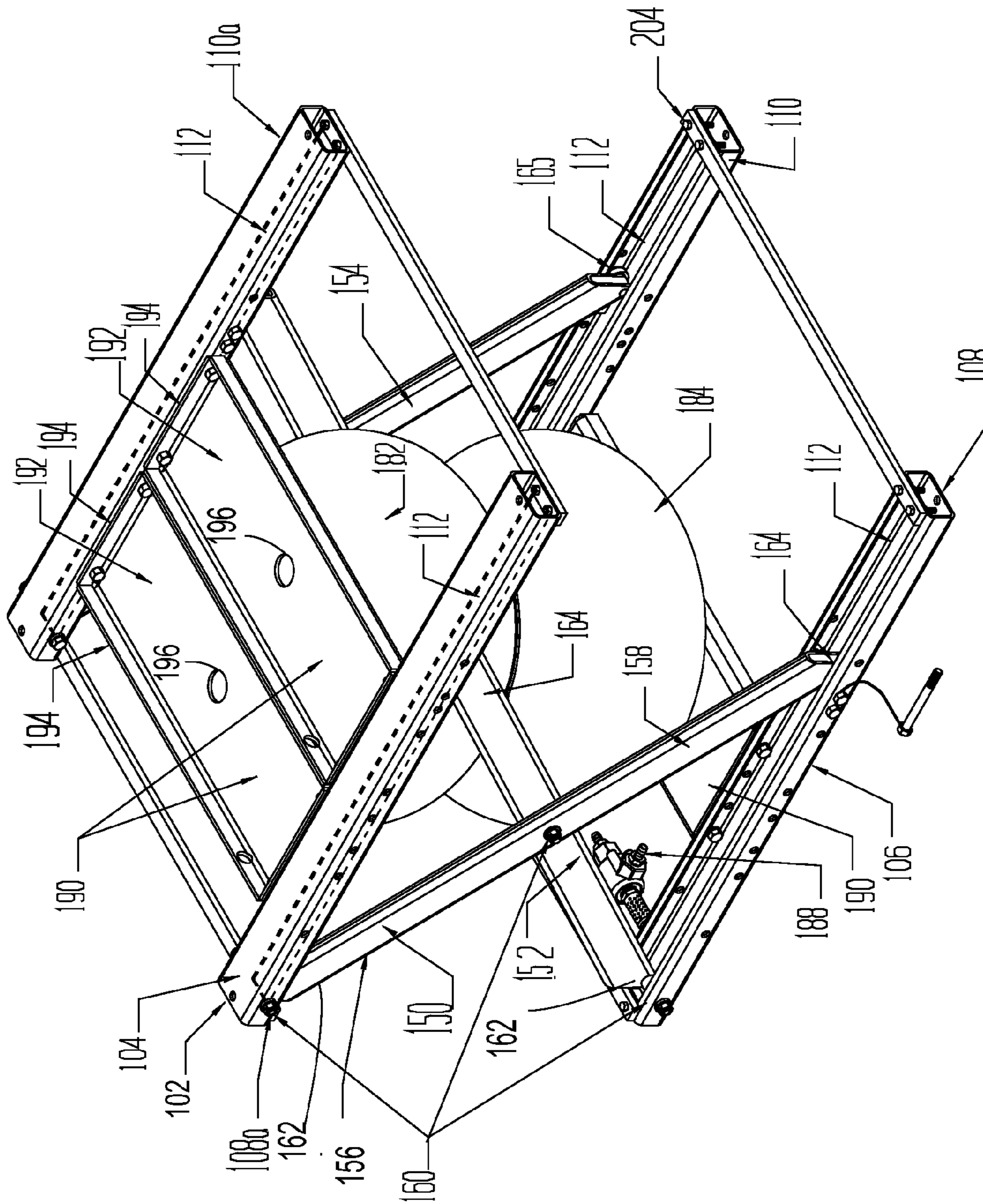

FIG-1

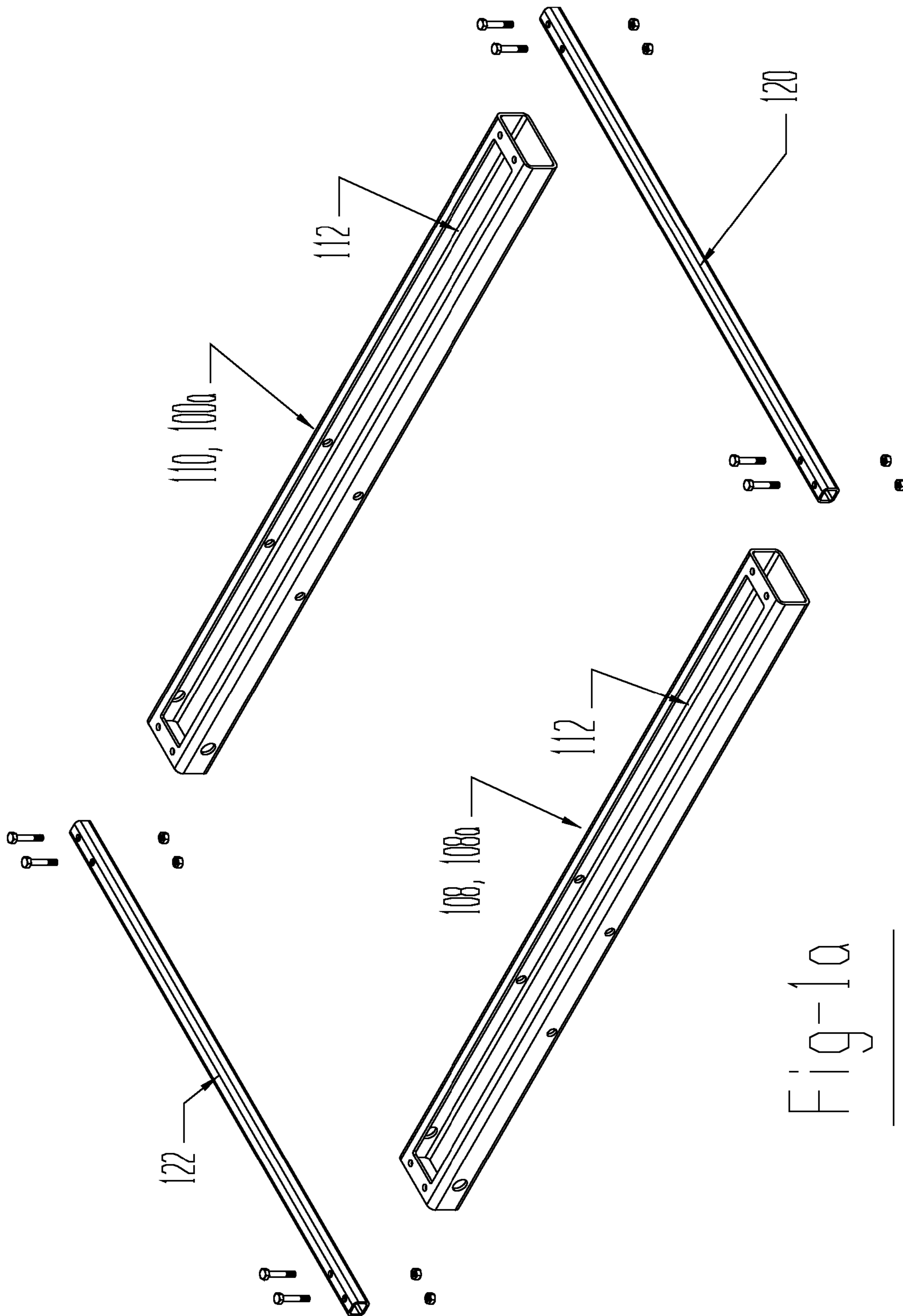

Fig-1a

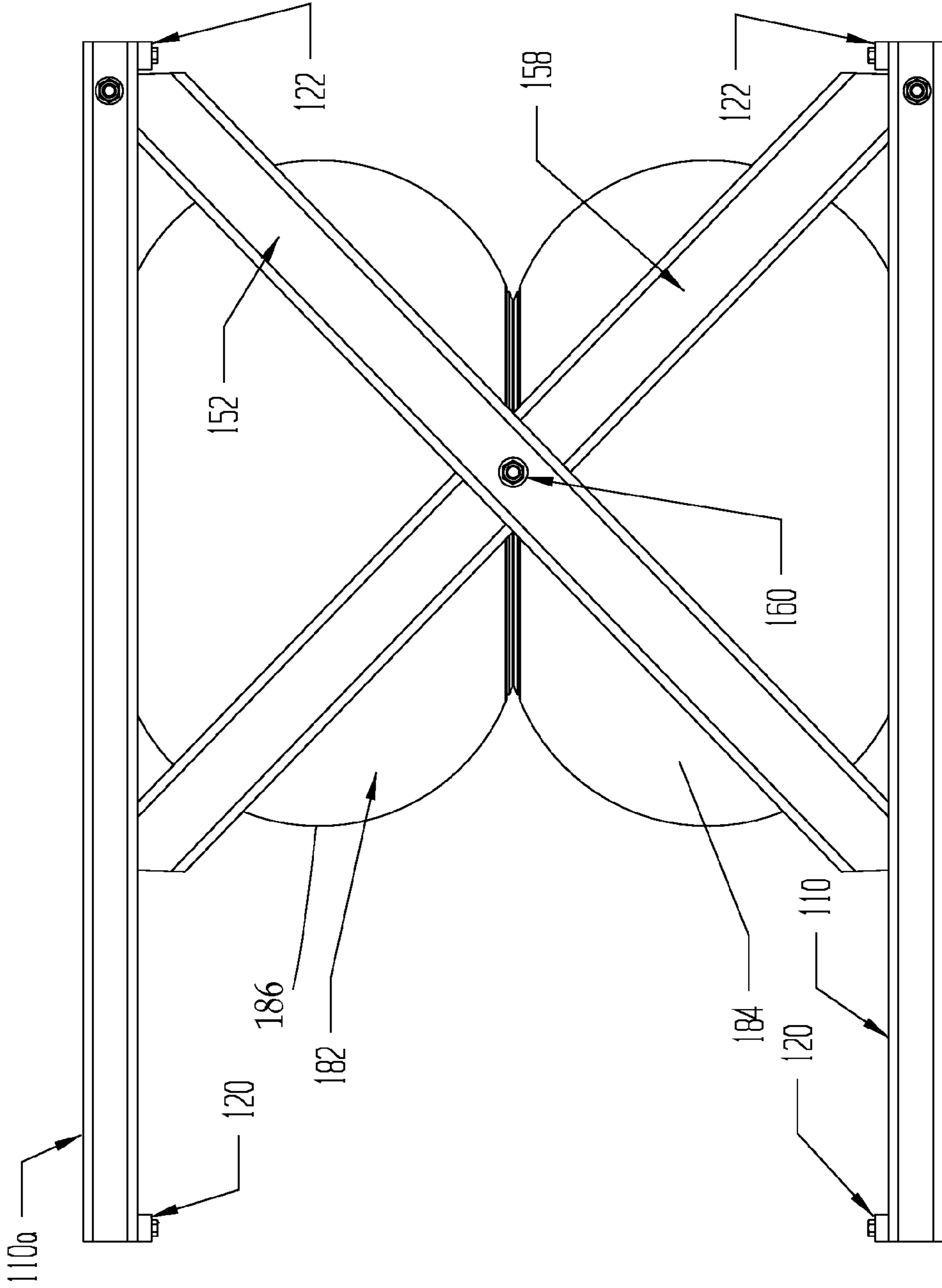

FIG-2

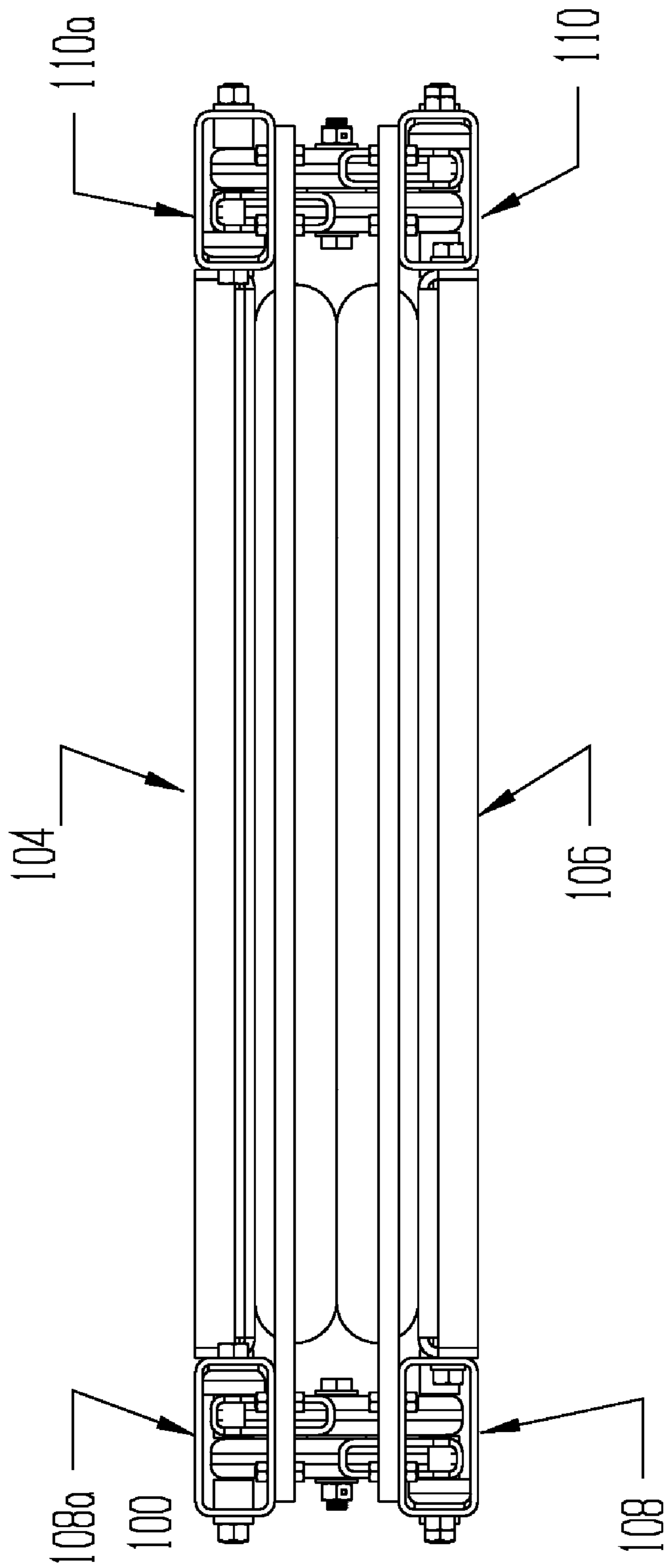

FIG-20

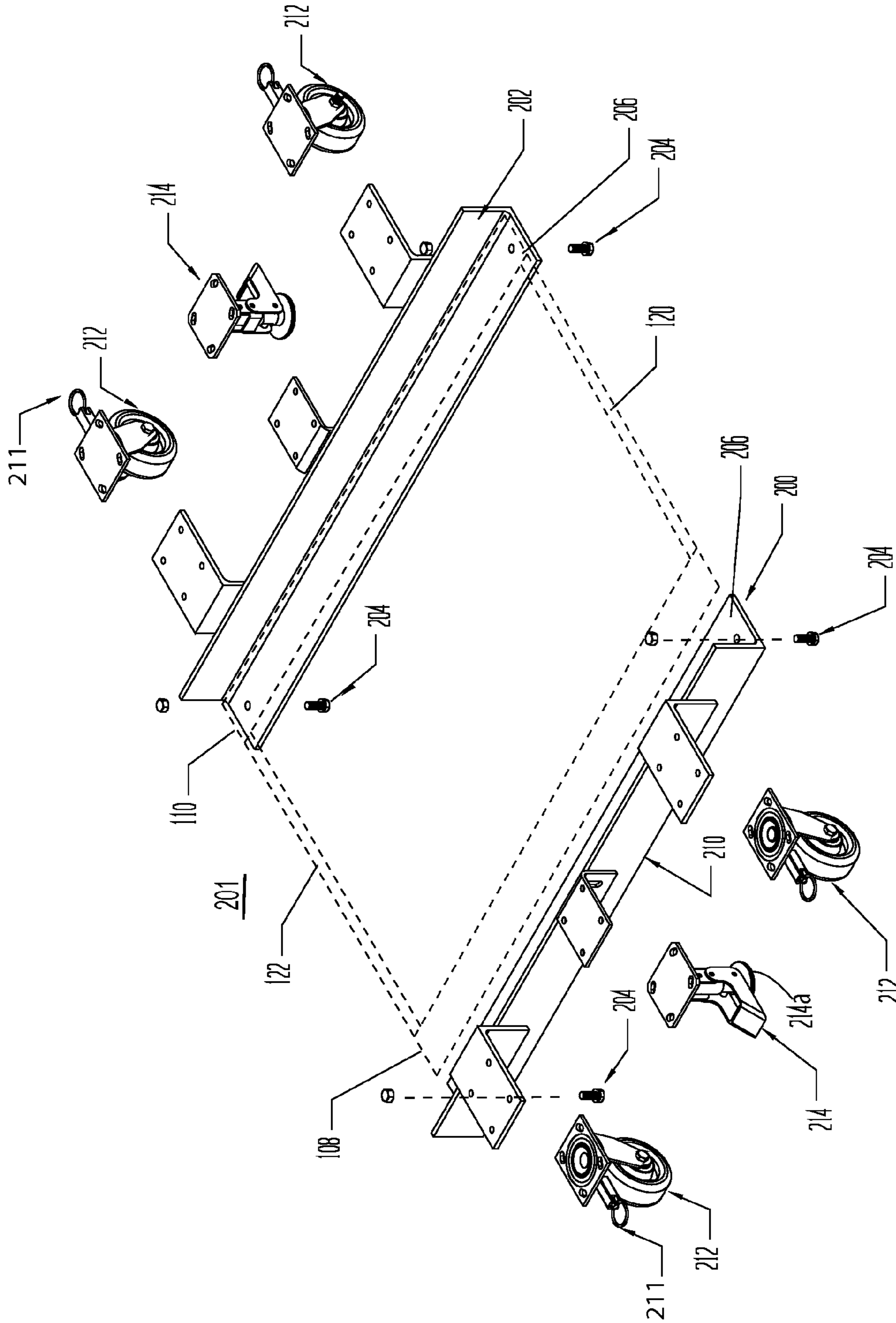

Fig-3

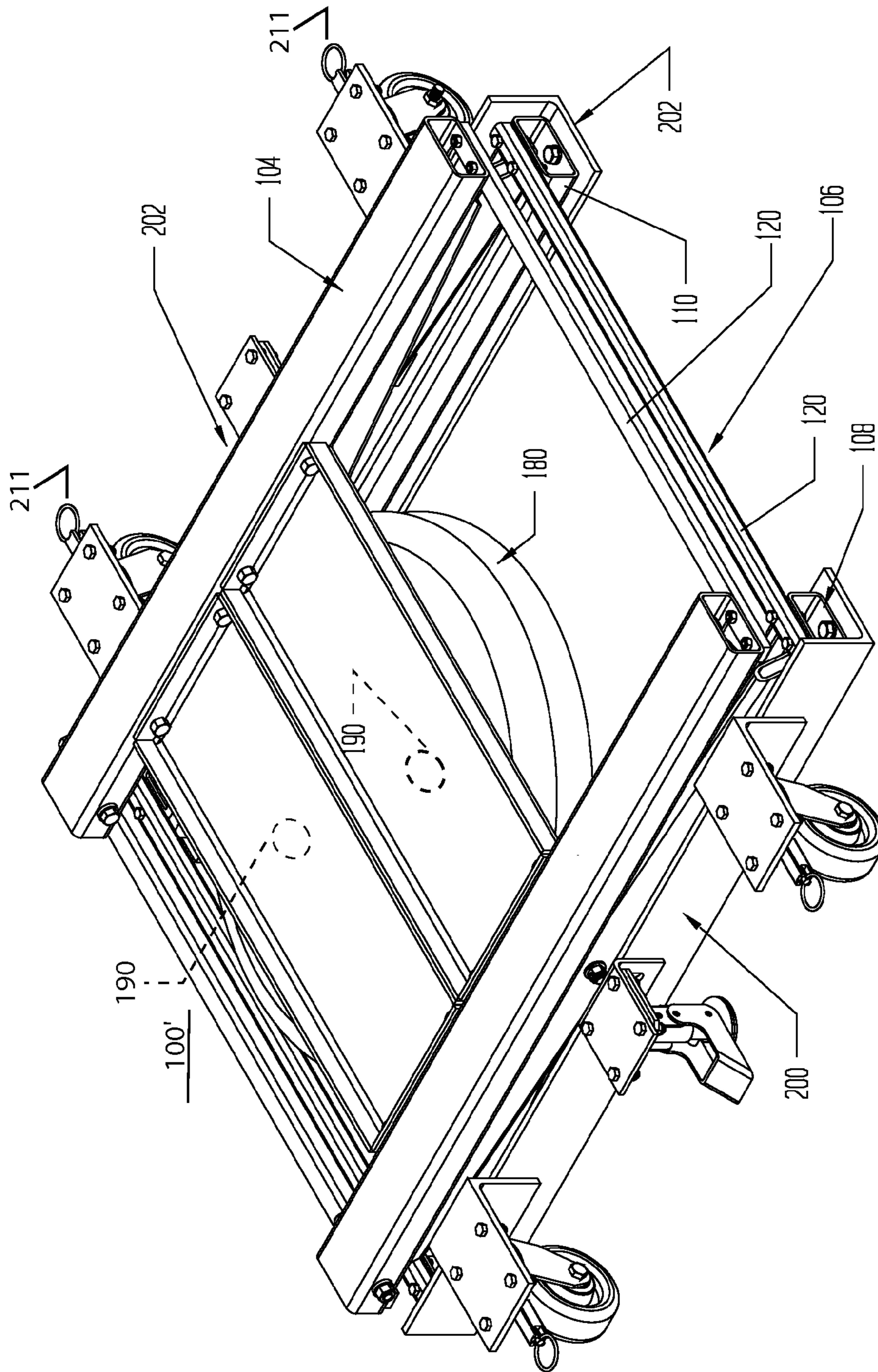

Fig-30

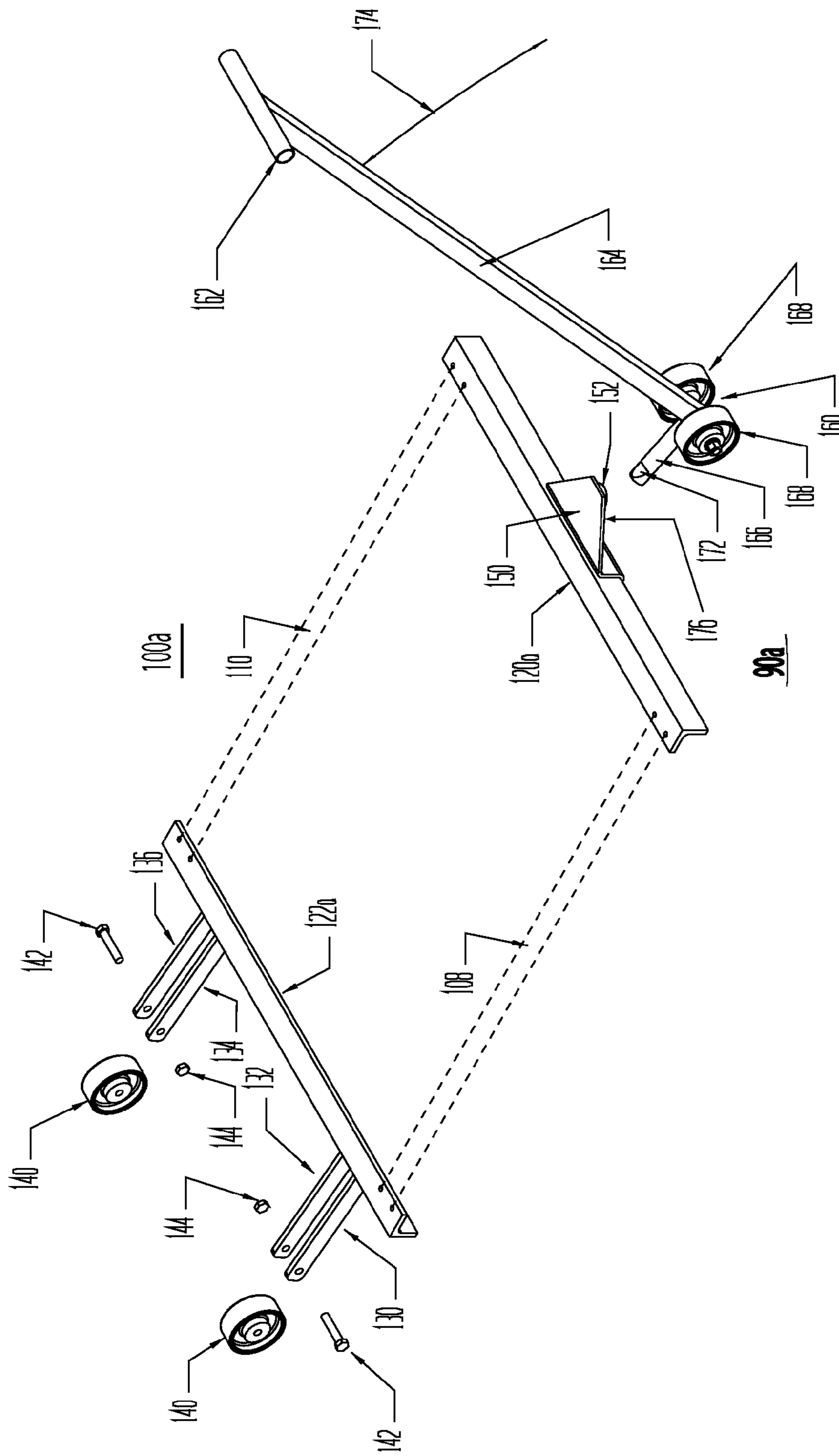

FIG-4

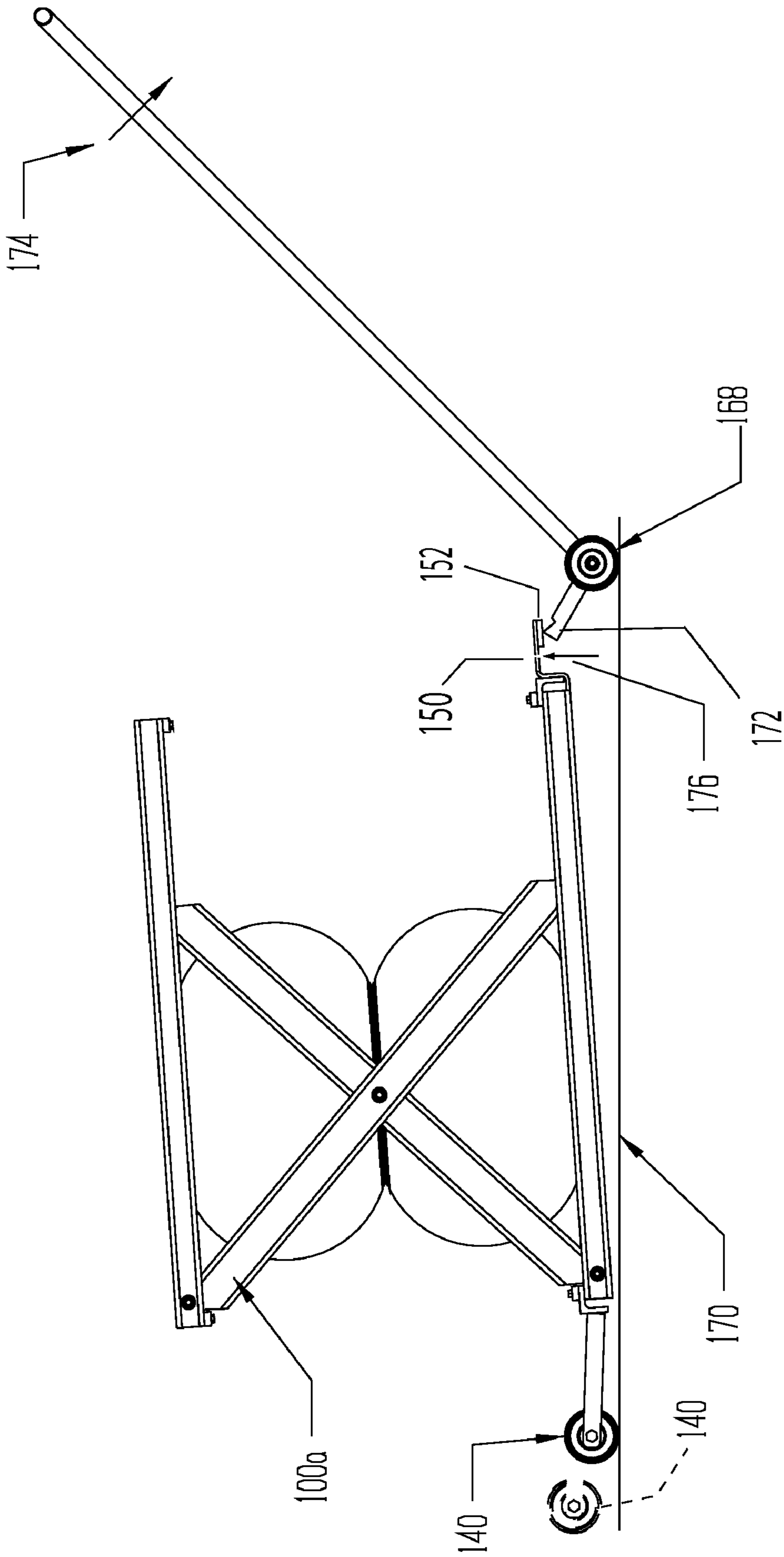

Fig-4a

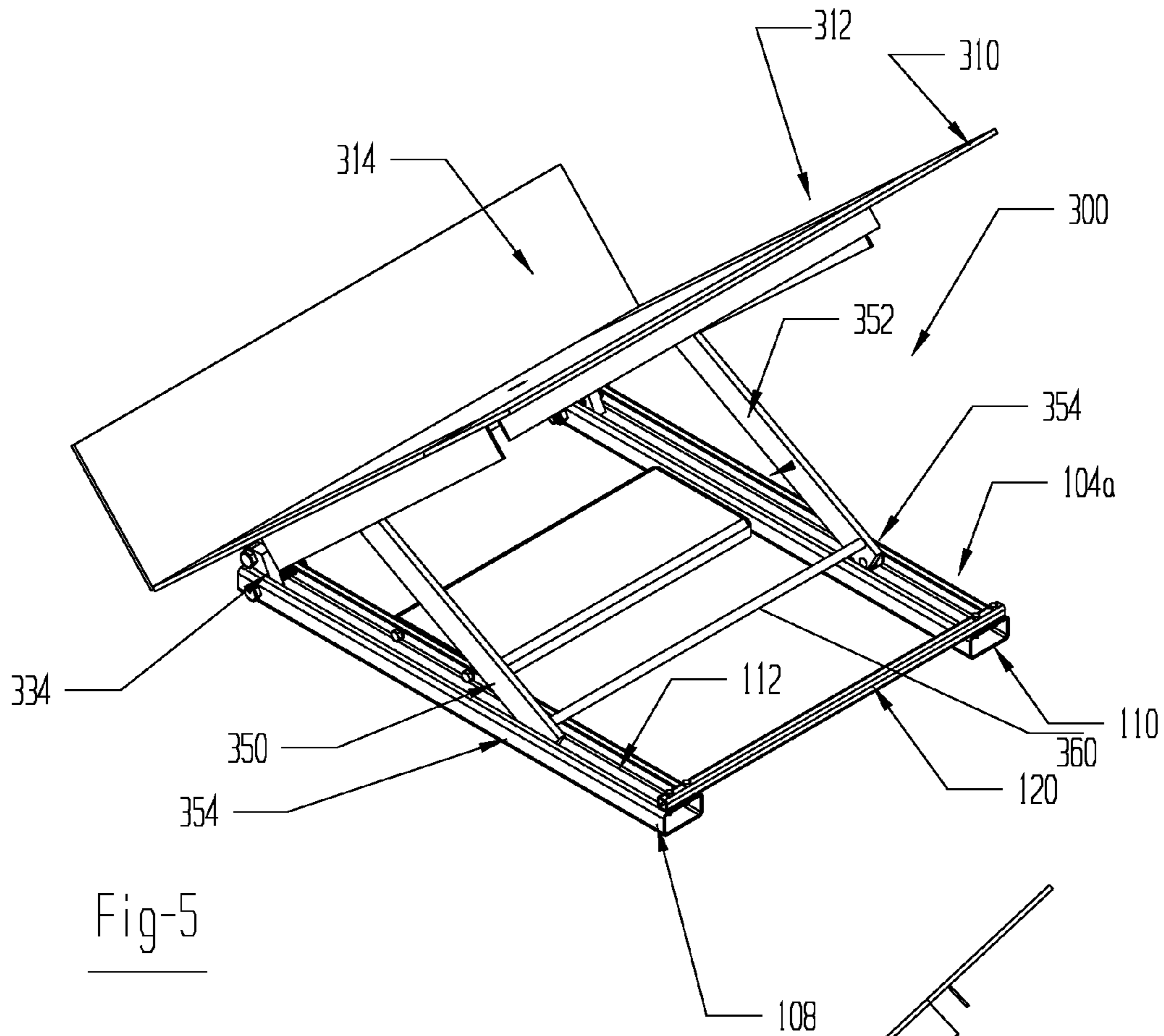

Fig-5

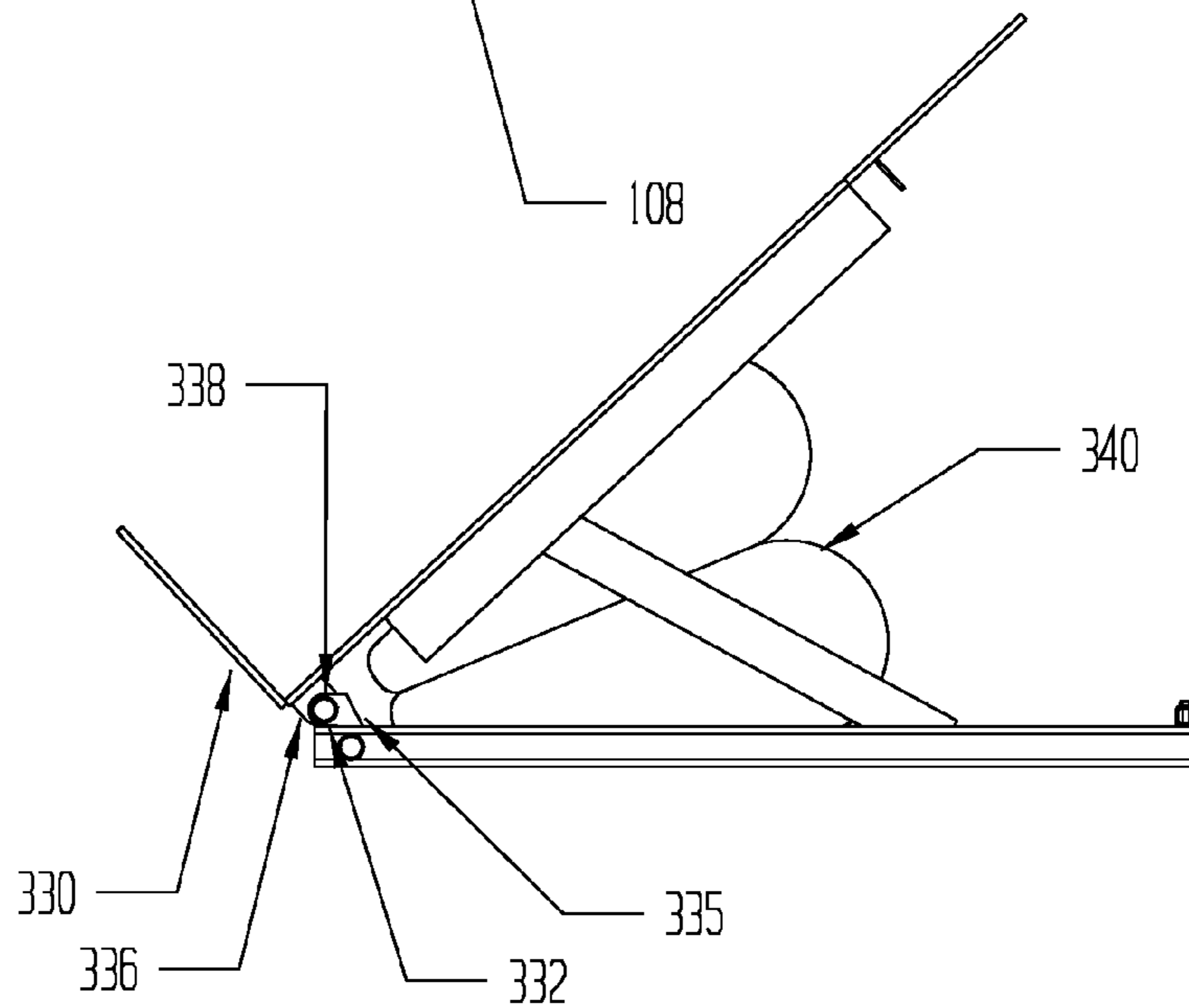

Fig-5a

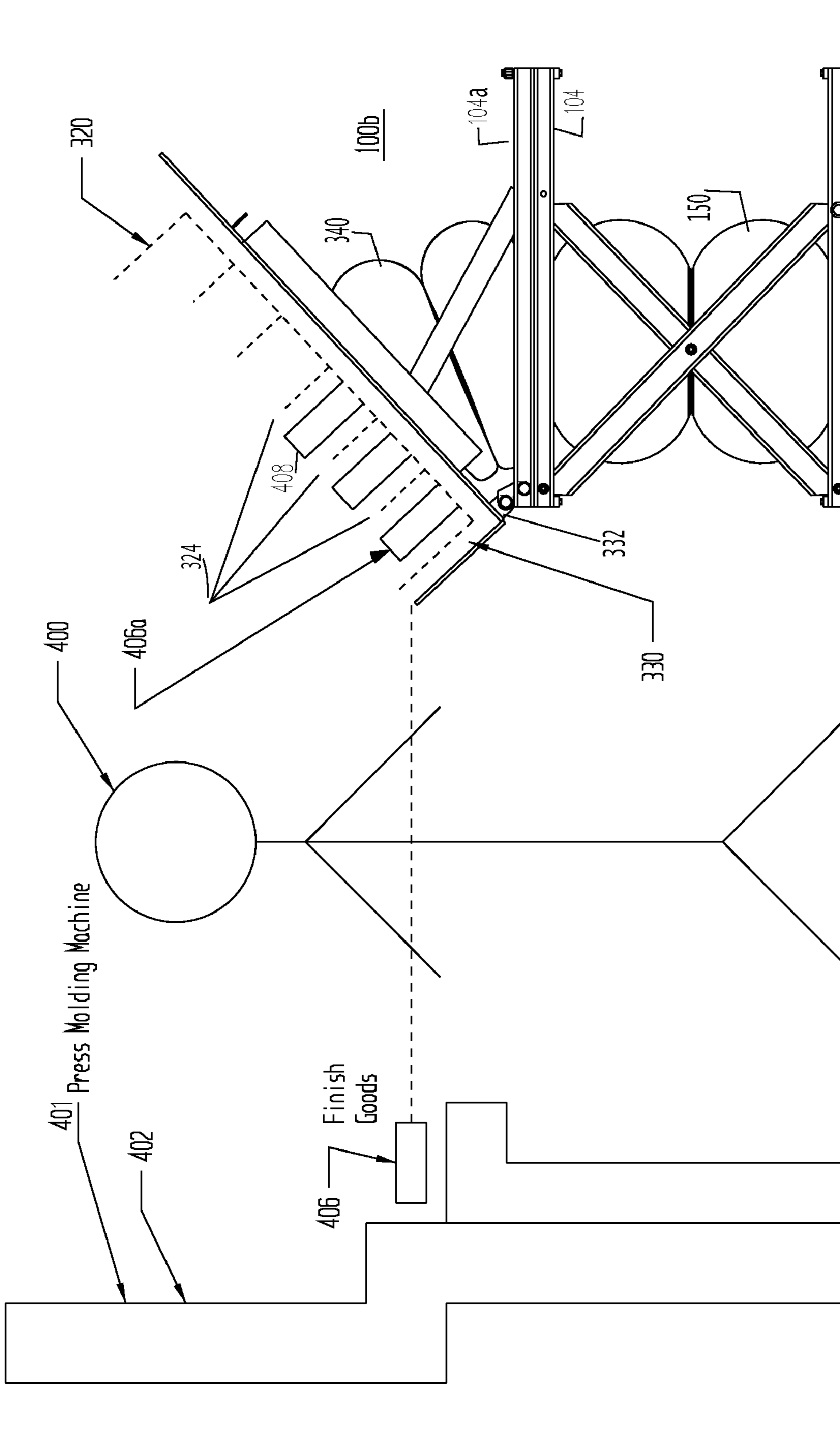

Fig-5b

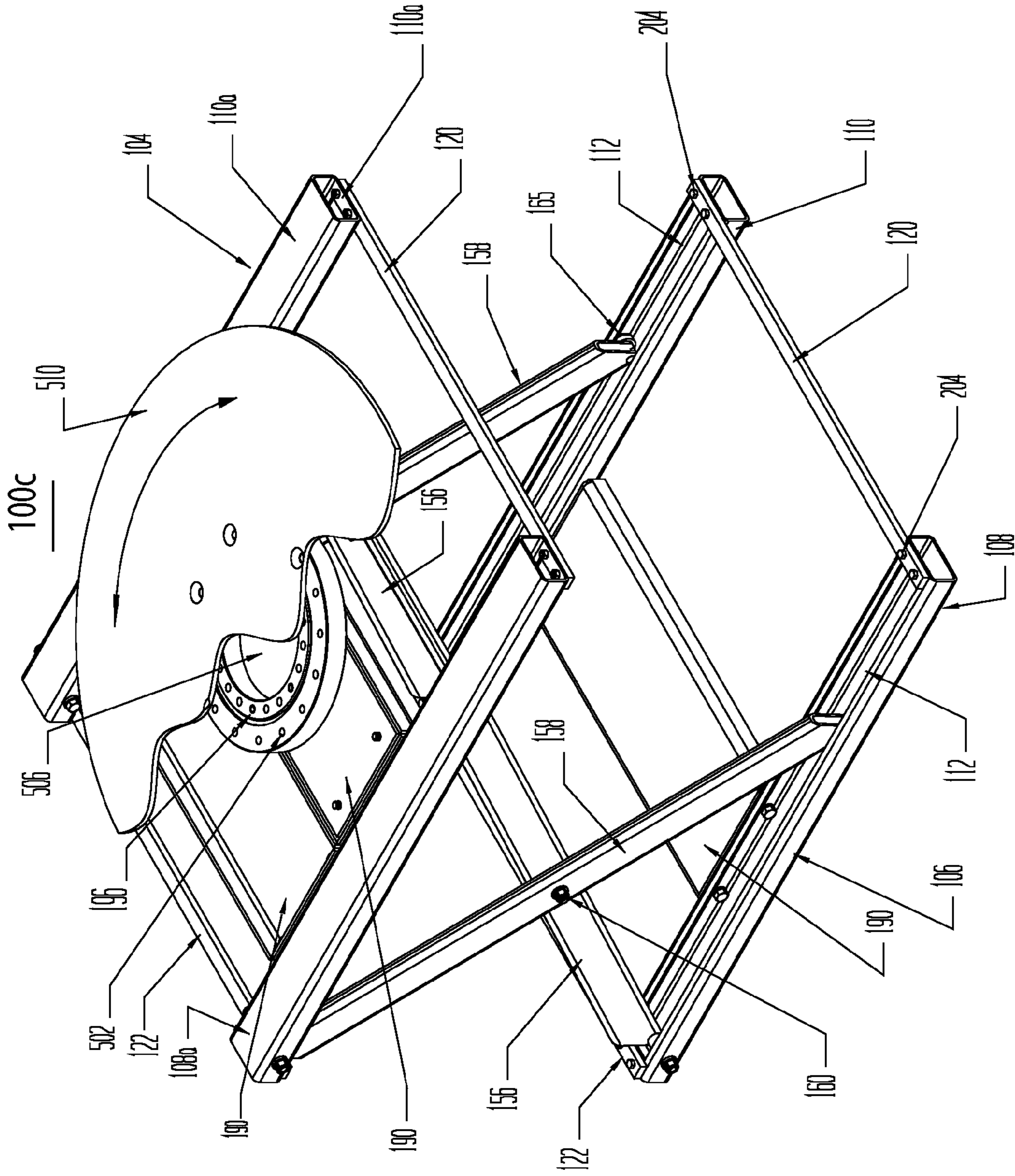
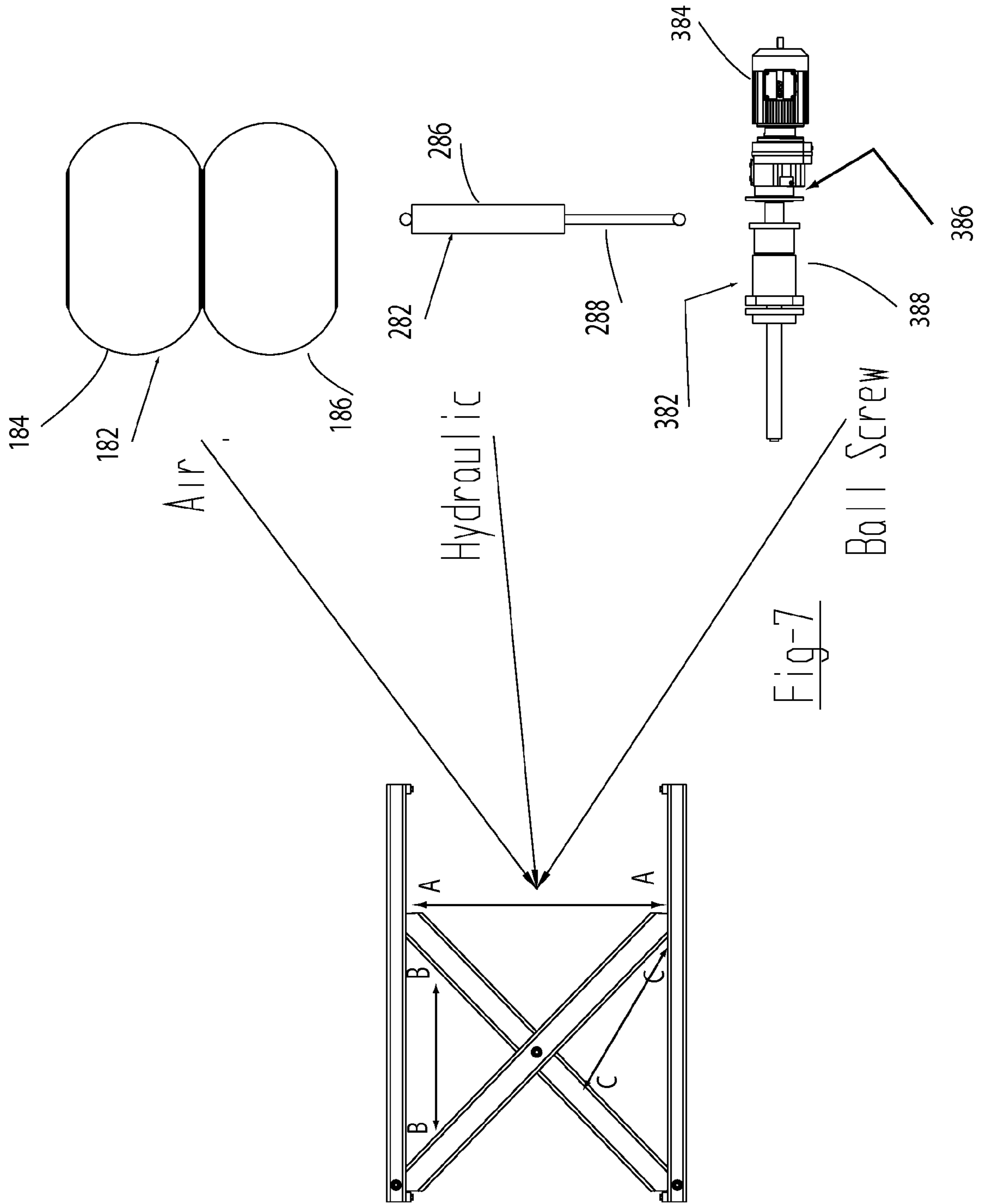

Fig-6



1

MULTIPURPOSE MODULAR LIFT
PLATFORM

This application claims the benefit of U.S. Provisional Application 61/051,597, filed on May 8, 2008. The disclosure of the above application is incorporated herein by reference.

BACKGROUND AND SUMMARY OF THE
INVENTION

The present invention generally relates to lifting mechanisms generally including lifts, jacks, and lift or lifting platforms, each of these terms are used interchangeably herein.

Industrial lifting platforms provide a powerful mechanism to lift and or otherwise orientate machinery, manufactured parts, pallets, boxes and the like. These devices also serve as adjustable platforms for operators as well. The prior art including U.S. Pat. No. 7,070,167, shows a variety of different types or classes of industrial lifts including stationary lifts, mobile lifts, lifts with fixedly secured platforms as well as lifts with platforms capable of tilting about a horizontal axis as well as rotating about a vertical axis. Each of these lifts is built to a fixed design to achieve a basic purpose and is not convertible or reconfigurable from one class of lift to another.

The manufacturer, distributor or customer of these various lifts must maintain and/or purchase an extremely large inventory of fully assembled lifts or parts therefor to enable the manufacture, assembly and use of a large set of products. The present invention has as one of its goals the reduction of inventoried parts while still enabling the assembly of a wide variety of lifts including those mentioned above. The present invention shows how the above mentioned lifts can be assembled utilizing modularity which permit for example starting with one type of basic lift and converting or reconfiguring its purpose and functionality.

More particularly, the present invention comprises in a first embodiment: a vertical lift including an upper frame member, a lower frame member, and the upper frame member is movable by a powering unit between a lowered position and a lifted position. The lift additionally includes a support mechanism that maintains the alignment of the upper frame member and a lower frame member. The powering unit is also referred to as a force generating subassembly. As can be appreciated the support mechanism can also be part of the power unit.

In the illustrated embodiment the support mechanism comprises a plurality of scissor mechanisms which primarily serve to support the upper frame and to maintain the alignment between the upper and lower frames. In the illustrated embodiment the scissor mechanisms are part of a lift support assembly and as such the illustrated lift is often referred to as a scissor lift. The powering unit or force generating subassembly in some of the illustrated embodiments is achieved by a plurality of inflatable chamber's (which resemble tires, air bags or bellows) that act directly between the upper and lower frames. The invention encompasses other support mechanisms and powering units. The lift is configured to accept one of a plurality of modular element or units to vary the functionality of the lower frame member and/or the upper frame member creating various lifts to provide commercial and functional flexibility and easily meet varying customer demand. In the illustrated embodiments the lift has a one-to-one ratio lift, with high lifting capacity, employing air bag (bellows) having diameters of up to 0.76 m (30 inches) to achieve a low profile, rapidly responsive lift. The lift is engineered to maximize structural strength and reduce cost by

2

optimally placing steel elements in critical locations throughout the lift as opposed to increasing the size and weight of all of the components.

BRIEF DESCRIPTION OF THE DRAWINGS

FIG. 1 shows a basic lift forming part of the present invention.

FIG. 1a shows a lower frame of the lift of FIG. 1 in greater detail.

FIG. 2 shows the lift in an elevated position.

FIG. 2a shows the lift in a lowered position.

FIG. 3 shows an alternate embodiment of the invention enabling the lift of FIG. 1 to be moved laterally using a carriage module.

FIG. 3a shows the carriage module referred to in FIG. 3 under a vertical lift.

FIG. 4 illustrates details of a dolly modular unit.

FIG. 4a shows a vertical lift, lifted by a modular dolly unit.

FIGS. 5, 5a and 5b show a lift with the addition of a modular tilt mechanism.

FIG. 6 shows a lift with the addition of a rotary platform.

FIG. 7 shows a number of power units usable with the present invention.

DETAILED DESCRIPTION OF THE DRAWINGS

FIG. 1 shows a vertical or scissor lift mechanism 100 usable with the present invention, the lift includes reconfigurable parts. This illustrated lift mechanism is a stationary lift, which vertically lifts a work piece from one position to another. The lift mechanism 100 includes a lift support assembly 102. The lift support assembly includes an upper frame 104 and a lower frame 106. The lower frame includes two reconfigurable support frame members 108 and 110. The support frame members 108 and 110 can be extruded tubes, preferably metal, which in cross-section, are generally box-shaped. An open channel or slot 112 is formed in each of the members 108 and 110. Members 108 and 110 are arranged parallel to each other and spaced apart. The upper frame 104 is similarly configured with two parallel and spaced apart frame members 108a and 110a, each member also generally box-shaped in cross-section with an open channel 112 formed therein. Respective portions of the scissor-lift mechanisms are received within the various open channels 112.

Each of the lower and upper frames 104 and 108 additionally include reconfigurable crossbars 120 and 122. In the embodiment shown in FIGS. 1 and 1a, the crossbars are removable and secured to opposing ends of the spaced-apart frame members 108-110 for the lower frame and 108a-110a for the upper frame. The frame members and crossbars used in each of the lower frame 106 and the upper frame 104 are interchangeable reducing the parts-count needed in inventory needed to convert one type of lift mechanism into another.

As mentioned above the lift mechanism 100 may include a scissor-lift mechanism receivable in slots 112. In general the scissor-lift mechanism is also called a connecting mechanism 150 as it connects, guides and aligns portions of the upper and lower frames. The illustrated connecting mechanism 150 includes a first scissor mechanism 152 movable within the channels 112 in the frame members 108 and 108a and a second scissor mechanism 154 movable within the channel 112 in frame members 110 and 110a. Scissor mechanism 152 includes two bars 156 and 158 that are pivoted about a joint or pivot generally shown as 160. Ends 162 of bars 156 and 158 cannot slide and are respectively rotationally connected to frame members 108 and 108a at hinge points 161. Ends 164

of the two bars **156** and **158** are configured to slide within the opening channels **112** as the first scissor mechanism **152** moves from a lowered to a raised position within frame members **108** and **108a**. Each end **164** is connected to a roller **165** to facilitate movement of ends **164**. The second scissor mechanism **154** is identically configured relative to the frame members **110** and **110a**. The bars **156** and **158** and other parts forming the two scissor mechanisms **152** and **154** are also interchangeable further reducing parts count in inventory.

The illustrated lift mechanism **100** includes a powering unit (force generating subassembly) or mechanisms **182**, **282** and **382** when operated cause the upper frame to move relative to the lower frame. The illustrated powering unit operates directly on the upper frame member and on the lower frame member. Alternately, the powering unit can apply a force or torque to one or more of the bars **156**, **158** of the various scissor mechanisms urging the bars of a particular (or both) scissor mechanism(s) to move apart or closer together thereby controlling the height of the upper frame member **104**. The force generating subassembly can be hand powered such as hand crank (not shown), or powered (see FIG. 7) by an electric motor with a transmission such as a ball screw, a pneumatic and/or hydraulic cylinder or air chamber or bellows depending upon the needs and resources.

The powering unit **180**, as illustrated in FIGS. 1, 2 and 2a, includes an inflatable bellows **182** which when inflated by compressed air raises the upper frame **104** relative to the lower frame **106**. To accommodate the bellows **182** the upper and lower frames include rectangular metal stampings, members or plates **190** attachable to the upper and lower frames. Each stamping, member or plate **190** has a flat surface **192** and four depending sides **194** (to facilitate attachment). Two of the sides are respectively secured to a corresponding side of frame members **108** and **110** of the lower frame and **108a** and **110a** of the upper frame. One or more stampings, members or plates **190** can be secured to the upper and/or lower frame. By way of example, one stamping **190** is secured to the lower frame and two stampings to the upper frame. Each surface **192** may include one or more openings **196**. The bellows acts between opposing surfaces **192** of the stampings **190** secured to the lower frame **106** and to the upper frame **104**. Bellows **182** may include multiple inflatable chambers including inflatable interconnected rubbers tires **184** and **186** which are known in the art, which receive pressurized air from a source of pressure such as a compressor through an air valve assembly **188**. The valve assembly **188** is communicated to the bellows **182** through hoses or pipes which extend through one of the openings **196**. In FIGS. 2 and 2a the lift mechanism **100** is shown in an elevated position and in a lowered position.

Reference is briefly made to FIG. 7, which diagrammatically shows alternate powering units (which can also be considered as powering modules) usable with the present invention including the bellows **182** as mentioned above. Additionally, the powering unit (force generating subassembly) can be a hydraulic device **282** with a movable piston **284** and hydraulic cylinder **286**. The hydraulic device can be placed between the upper and lower frame applying force directly thereto (at the location of arrows A-A) in the manner the bellows is shown in the various figures or placed between the scissor elements (at the location of arrows B-B) or between a scissor element and one of the upper or lower frames (see arrow C-C). FIG. 7 also shows electrical force generating unit **382** including an electric motor **384** and a transmission **386** such as a ball screw mechanism **388** that can be connected to the lift in the various ways suggested for the hydraulic device.

Reference is now made to FIG. 3 which shows how the functionality of the lower frame **106** including the frame members **108** and **110** are reconfigured and repurposed. More specifically, FIG. 3 illustrates a carriage module **201** comprising two carriage members **200** and **202** each of which are adapted to be positioned under lower frame **104**, and more particularly under frame member **108** and/or frame member **110** and preferably secured to these frame members utilizing one or more removable fasteners **204**, such a threaded fastener (bolt and nut) received in a threaded opening in frame members **108** and **110**. The use of fasteners as mentioned is preferred to permanently secure a carriage member to the lower frame **106** and permits the lift **100** and carriages to move as an integral unit. However, another alternate of the present invention is to slide the carriages below the lower frame using the weight of the lift to maintain the carriages in the correct orientation, thereby eliminating the need for such fasteners. Each carriage member is formed with a lower support surface **206** which is configured to extend under frame member **108** and/or or frame member **110**. In the illustrated embodiment the lower support surface **206** is part of an L-shaped steel bracket **210**. As can be appreciated the carriage members are identical and interchangeable which reduces parts count and inventory. Each carriage member **200** and **202** is configured to receive two casters (wheels) **212** and a locking or break device **214** which when activated prevents the frame from rolling on the wheels. The casters enable the lift mechanism **100'** (see FIG. 3a) supported on the carriage members to be moved laterally. The locking or break members hold the carriage members and lift mechanism at the desired location by interacting with the floor (such as by forcing a pad **214a** against the floor) in a known manner. The locking or break device **214** can be incorporated within the casters which when activated prevents the caster (wheel) from rotating. As can be seen from the above, the carriage members **200** and **202** add additional functionality to the frame members **104**, **106**, **108** and **110** converting a stationary lift mechanism **100** into a mobile lift mechanism with the addition of modular carriage members or units. The two carriage members are sometimes referred to collectively as a carriage **201**. Reference is briefly made to FIG. 3a which shows the carriage members or units **200** and **202** secured to lift **100**. In FIG. 3a the upper frame is shown in a lowered position. FIG. 3a also shows that if desired, the stamping **190** need not include an opening such as **190** shown in phantom line, but if this alternate is chosen one added part (the stamping without opening) is added to inventory. FIGS. 3 and 3a show a plurality of tie-down loops **211** which can be used to further secured the lift mechanism too the floor.

The function performed by the cross members or crossbars **120** and **122** lift mechanisms **100** and **100'** is to maintain the proper spacing between the lower frame members **108** and **110** as well as **108a** and **110a**. FIG. 4 illustrates another add-on or replacement modular unit such as a dolly module **90** comprising a front wheeled section and a rear dolly section. This module **90** can also be used to convert a stationary lift into another mobile lift mechanism **100a**. In this embodiment, crossbars **120** and **122** shown in FIGS. 1 and 1a are replaced by crossbars **120a** and **122a**. As can also be appreciated, the crossbars **120** and **122** need not be replaced, in which case crossbars **120a** and **122a** can be secured on top of the crossbars **120** and **122**. In the illustrated embodiment the alternate crossbars **120a** and **122a** are secured directly to the lower frame members **108** and **110** using the same fasteners used to secure crossbars **120** and **122** (obviously with crossbars **120** and **122** removed). Crossbar **122a** is shown in the form of an L-shaped bracket configured to be secured to the

frame members **108** and **110** by one or more threaded fasteners. Crossbar **122a** further includes two sets of extending spokes **130**, **132** and **134**, **136**. A wheel such as **140** is secured between each set of spokes and appropriately secured thereto, such as by utilizing a shoulder bolt **142** and nut **144**. Crossbar **120a** is also formed using an L-shaped bracket configured to also be secured to lower frame members **108** and **110** opposite crossbar **122a**. Crossbar **120a** includes a further L-shaped flange or bracket **150** having a projection **152** such as a hitch, ball or pin, protruding from its underside. The above components are designed to cooperate with a manually movable dolly generally shown as **160**. The dolly includes a handle **162** and handle bar which forms a first lever **164** operatively connected to a smaller lever **166** at a pivot point formed by an axis extending through casters (wheels). The levers are supported by a plurality of casters (wheels) **168**. The above crossbars in combination with the dolly **160** convert the normally stationary lift mechanism **100** into a mobile lift mechanism **100a** as more particularly illustrated in FIG. **4a**. As can be appreciated, by securing the wheels **140** and projection **152** to respective cross-bars the spacing between the wheels and projection is maximized. The cross-bars **120a** and **122a** can be secured to the lower frame members **108** and **110**. In this case cross-bars would not be removed.

When lift mechanism **100a** is located on the support surface (such as the floor) **170** in its normal operating condition, both wheels **140** are elevated from the support surface **170** and the lower sides of members **108** and **110** rest upon the surface **170** in FIG. **4a**. The elevated condition of the wheels is diagrammatically grammatically shown by phantom wheel **140** elevated from surface **170** also in FIG. **4a**. With the lift **100a** in this configuration the bracket or flange **150** is designed to be elevated from the floor **170**. When it is desired to relocate lift mechanism **100a**, the dolly is manipulated so that the smaller lever **166**, see FIG. **4**, is below the projection **152**. Dolly **160** includes a connector of known construction that is engageable with projection **152**; this connector is generally shown by **172**. With the dolly in the position as described, the handle bar i.e. the long lever **164** is pushed downwardly generally shown by arrow **174** in FIG. **4a**, creating an upward force, see arrow **176**, lifting flange **150** off of the floor, tilting lift mechanism **100a** and placing the wheels **140** on the surface **170**. In this condition the lift mechanism **100a** is now supported by the two sets of wheels **140** and **168** and can be moved laterally to a new work location at which time the dolly is removed and lift **100a** will once again rest on the floor.

When the upper frame **104** of lift mechanism **100** is moved up and down, the upper frame maintains a horizontal orientation and functions to move its cargo (or occupant standing thereon) from one vertical position to another; this is true of lift mechanisms **100'** and **100a** as well. The following embodiment illustrated in FIGS. **5**, **5a** and **5b** modularize the functionality of the upper frame **104** and enable a work piece such as a storage container to first be mounted to any of the above lift mechanisms, and if desired tilted to desired orientation toward or away from a worker enabling the worker to ergonomically fill or remove products into or from the storage container.

FIG. **5** shows a modular tilt mechanism **300** and includes a supplemental upper frame **104a** that is configured to be connected to the first mentioned upper frame **104**. The supplemental upper frame **104a** is constructed of support members **108**, **110** and crossbars **120** and **122** as is the case with the upper frame **104**. As can be appreciated this construction also serves to minimize the number of parts needed inventory. The tilt mechanism **300** includes a table **310** having a first support

member **312** and a second support number **314**. When the tilt angle is 0° , member **312** is horizontal while member **314** is vertical. In this orientation a storage container **320** (shown in FIG. **5b**) can easily be placed upon the table **310**. The storage container, see FIG. **5b** can include one or a plurality of partitions **322** into which products can be placed. End **330** of table **310** is secured to the supplemental upper frame **104a** using two opposing hinges **332**, only one of which is shown in the many figures, the other hinge being of identical in construction. The hinged table **310** is movable from a horizontal or zero degree position to an elevated position. The hinged table can be moved to different positions by many known force generating subassemblies including pneumatic, hydraulic cylinders or electric motors. In FIGS. **5**, **5a** and **5b** the power unit (force generating subassembly) **340** for the tilt mechanism is one or more inflatable chambers or tires, similar in construction and operation to lift mechanism **150**. As can be appreciated the other power units **282** and **382** can also be installed in the tilt mechanism further increasing the modularity of the present invention yielding additional members of the family of lift mechanism.

The lower portion **334** of hinge **332** is formed by a metal block **335** that is received within the end of slot **112** in each of the support members **108** and **110**. The blocks **335** are secured to each of the frame members **108** and **110**. The upper portion **336** of each hinge **332** includes a projecting arm **338** that is rotationally fitted to the lower portion **334**, a pin extends through the upper and lower portions to provide the hinge. As the chambers of the device **340** are inflated the table moves from one angular orientation to another. The supplemental upper frame **104a**, as a module, is fixedly secured to the upper frame **104** such as be bolting the facing frame member **108** and **110** together or by bolting facing standings **190** together. The tilting mechanism **300** additionally includes two identical, hinged bars **350** and **352** each having an end **354** slidably received within a slot **112**. Each end may be supported on a roller such as **165** in the manner shown in FIG. **1**. To maintain the coordinated movement of ends **354** each end is connected to the other by a crossbar **360**. As table **310** is moved to its lowest position ends **354** will move to the right-hand side of slot **112** relative to FIG. **5a** and when the table **310** is moved to its maximum angular positioned the ends will achieve the orientation as illustrated for example in FIG. **5b**. In the situation where the weighted load on the table **310** is known to be low, the powering units **182**, **282** and **382** can be eliminated and table moved manually. In this embodiment the lower end of each bar **350** and **360** can be pinned in place or a ratchet mechanism included in the frame members **108** and **110** of the tilt mechanism to hold the table **310** in its desired location until later changed.

In FIG. **5b** a lift **100b** with the tilt mechanism **300** is shown next to an operator/worker diagrammatically illustrated by **400**. The operator is positioned between the tilt mechanism and production machine **401** such as a stamping press or molding machine, the output of which is a partially finished or finished products or goods **406**. The operator **400** takes this product and inserts same into either into the container or into one of the partitions **322**, if provided, in the storage container **320**. As can be appreciated if the worker **400** found it inconvenient or unsafe to insert an additional work piece shown as **408** into another or second row of the storage container the worker now has the ability to raise or lower the lift mechanism **100a** and to also change the angular orientation of the table **310**. For example, when a second or upper row is positioned further away from the operator **400** the operator might stretch too far and injure himself/herself. To avoid this the operator **400** can now cause the lift mechanism **110b** to achieve a

different vertical position (up or down) thereby changing the relative position of the storage box **320**. If this did not result in a more efficient condition to access the second or upper row, the position of the tilt mechanism can be varied again making it more convenient and safe for the operator to insert the product into an upper row. In this manner the operator can control the angular orientation and vertical height of the container to enhance placement of product therein or removal of product therefrom and to accomplish this function in a safe manner. As can also be appreciated the basic lift mechanism **100b** with modular tilt mechanism **300** can also be converted to one of the mobile lifts mentioned above. Further, the powering units can be one of the above mentioned variations (bellows, pneumatic, hydraulic, electric or manual).

Reference is made to FIG. **6** which illustrates a further embodiment of the invention in which the function of the upper frame **104** is converted from a stationary platform to a rotary platform with the addition of a modular rotary unit. FIG. **6** again shows a lift **100c** using the basic lift **100**, with the powering unit removed. The upper frame **104** is configured to receive a rotary platform modular unit **500** comprising a rotary ball bearing or bushing member **502** comprising an inner and an outer race that is capable of rotating relative to the inner race. The inner race can be secured to the upper frame **104** by one or more bolts or fasteners **506**. Bolt **506** can extend from opening **196** (in the inner bearing race) through or in one of the steel stampings **190**. A circular (or other shaped) platform **510** is secured to a movable with the bearing **502**. The lift with the rotary unit **500** is referred to by number **100c**. As can be appreciated the lift mechanism **300** can be secured to the rotary unit **500** further increasing the family of lift mechanisms. This new combination can be stationary or mobile and powered by any of the powering units mentioned above.

From the above it can be appreciated that a family of operationally flexible, lift mechanisms can be fabricated using modular components according to the teachings of the present invention.

The invention claimed is:

1. A vertical lift comprising:

upper frame member, a lower frame member, and a lift mechanism configured to change vertical spacing between the upper and lower frame members from a first position to a second position, the upper or lower frame member or parts thereof being reconfigurable or configured to accept a modular unit; and

at least one modular unit configured to operate in conjunction with the lower frame or the upper frame for changing functionality of one or both of the lower frame member or the upper frame member;

wherein one of the modular units is a lower frame modular unit configured to attach to the lower frame to vary the functionality of the lower frame from resting immovably upon a support surface to: a) horizontally translatable relative to the support surface on wheels supported from first location to a second location or b) temporally lifted off the support floor onto a wheeled support and trans-

latable from the first location to the second location and lowered back onto the support surface at the second location;

wherein the lower frame includes a first and second frame bar spaced apart, each bar including a first and a second end, the lower frame including removable first and second cross-bars attached to the first and second frame bar, wherein the modular unit includes a removable third crossbar to replace the first cross-bar mountable and a fourth cross-bar to replace the second cross-bar; wherein a pair of wheels extends from the third crossbar and wherein a dolly lift mechanism is operably connects with the fourth cross-bar and the dolly lift mechanism is configured to lift the lower frame at the pair of walls.

2. The lift according to claim **1** wherein one of the modular units is an upper frame modular unit including one or more modular units configured to attached to the upper frame member to: a) provide a platform rotatable about a vertical axis relative to the upper frame member, b) provide a platform rotatable about a horizontal axis relative to the upper frame member and c) provide a platform rotatable about a horizontal axis and also rotatable about a vertical axis.

3. The lift according to claim **1** wherein the lower frame member includes a first frame bar and second frame bar spaced apart from each other, each frame bar including a first and a second end, the lower frame including removable first and second cross-bars attached to the first and second frame bar, wherein portions of the modular unit replace the first and second cross-bars.

4. The lift according to claim **1** wherein the lower frame includes a first and second frame bars spaced apart from each other and wherein the modular unit includes a carriage configured to be placed below the frame bars to raise the lower frame member above the support surface, the carriage including a set of wheels or casters to enable lateral movement of the lift.

5. The lift according to claim **4** wherein the carriage includes a brake prevent the lift from moving.

6. The lift according to claim **4** wherein the carriage include a first and second carriage member each carriage member receivable under a different portion of the lower frame member, each of the first and second carriage members including wheels or casters.

7. The lift according to claim **1** wherein the dolly lift mechanism includes at least one wheel.

8. The lift according to claim **2** including a modular rotary bearing unit configured to attach to the upper frame member, the unit including a the platform which is rotatable about a vertical axis relative to the upper frame member.

9. The lift according to claim **2** wherein the platform includes a ledge to hold a container, the platform secured to an intermediary upper frame by a hinge, the intermediate upper frame configured to be placed upon the upper frame member.

10. The lift according to claim **1** wherein the lift includes a scissor lift mechanism and a powering unit including one of a pneumatic unit, an electric unit or a hydraulic unit.

* * * * *