

PART #: LSA31-XX-29-3447

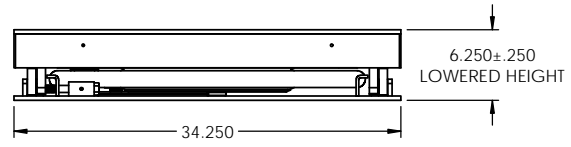
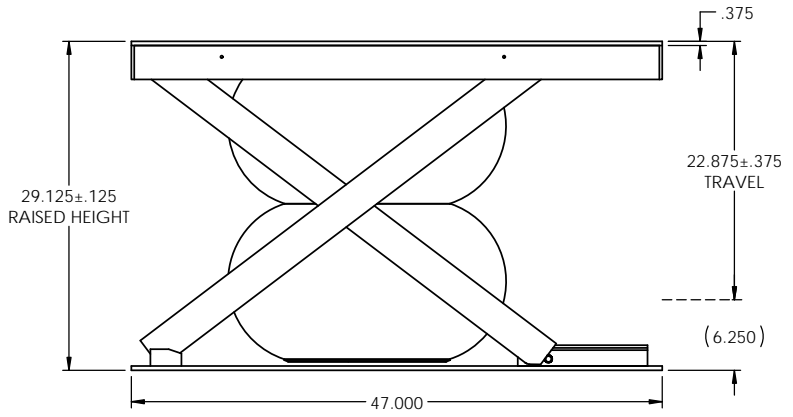
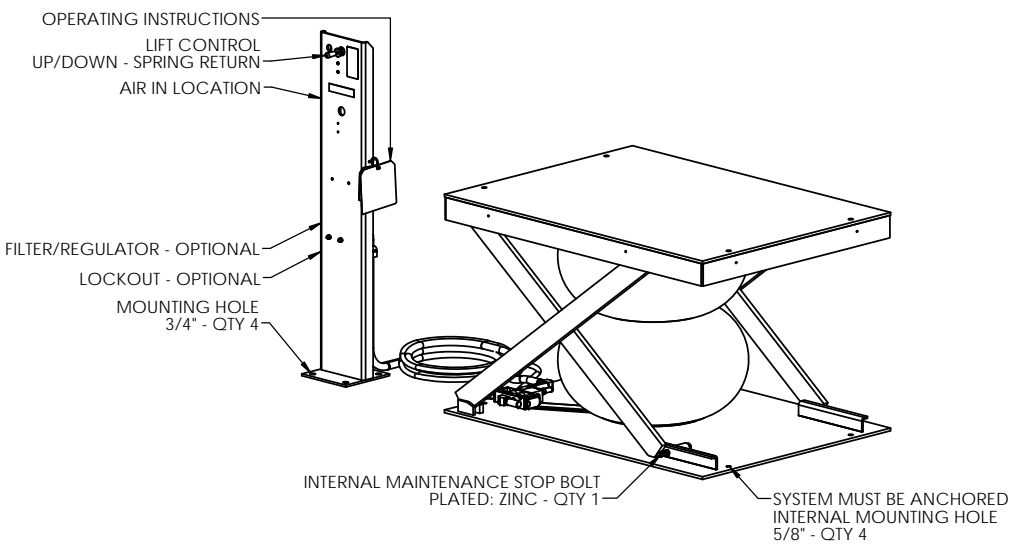
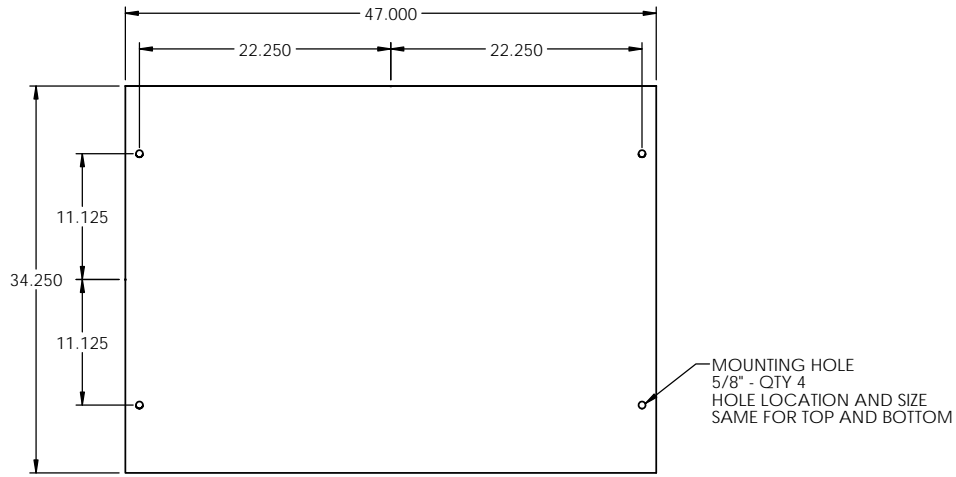

SPECIFICATIONS - STANDARD

- CAPACITY: 1,000 - 4,000 LBS
ALL LOADS MUST BE EVENLY DISTRIBUTED
LIFT MAY NOT RAISE TO FULL HEIGHT WITH MAXIMUM CAPACITY LOAD
- CONTROLLER: HAND
- CONTROLLER MOUNT: PEDESTAL
- INTERNAL VALVE: PILOTED EXHAUST
- AIR FEED LINE: 1/2" MINIMUM
- AIR PRESSURE: 70 - 100 PSI
- CONTROLLER HOSE: 12 FEET
- SKIRT: OPTIONAL
(ADD 3-1/2 INCHES PER SIDE TO BASE OF LIFT DIMENSIONS FOR SKIRTING)
- COLOR: LIFT: HERKULES SAFETY ORANGE
SCISSORS: HERKULES SAFETY ORANGE
PEDESTAL: HERKULES SAFETY ORANGE
- SAFETY FEATURES: PRESSURE RELIEF VALVE - QTY 1
CHECK VALVE - QTY 1
INTERNAL MAINTENANCE STOP BOLT - QTY 1
- WEIGHT SHIPPED: 670 LBS (APPROXIMATE)

THE NEED FOR SAFETY DEVICES VARIES WITH EACH APPLICATION OF THIS PRODUCT THIS DRAWING MAY NOT INCLUDE ALL APPROPRIATE SAFETY DEVICES FOR YOUR APPLICATION.
NOTE: SOME DETAILS ARE NOT INCLUDED ON THIS DRAWING FOR MORE DETAILED SPECIFICATIONS, PLEASE INQUIRE
PROPRIETARY
THE INFORMATION CONTAINED ON THIS DRAWING IS PROPRIETARY. IT IS THE SOLE PROPERTY OF HERKULES EQUIPMENT CORPORATION. ANY REPRODUCTION IN PART OR AS A WHOLE WITHOUT THE WRITTEN PERMISSION OF HERKULES EQUIPMENT CORPORATION IS PROHIBITED AND MAY BE UNLAWFUL

TOLERANCES UNLESS OTHERWISE NOTED
X ± .250
XX ± .125
XXX ± 0.030
XXXX ± 0.0050
ANGLE ± 1°

DESCRIPTION: LIFT SCISSOR AIR

DRN: TEP	PART NO.: LSA31-XX-29-3447
DATE: 5-19-16	CHD BY: DWG NO.: 20117273 REV: SHEET: 1 of 1